

Revision History

Revision	Date	Reason for redrawing	Page Update	Drawed	Checked	Approved
01	2013.06.05	Preliminary	--	Austin Lin	Brian Lee	Barry Chang
02	2013.06.11	Remove Damping Resistors at NAND Flash Side	Page4,5	Austin Lin	Brian Lee	Barry Chang
02	2013.06.24	Modify RA4 footprint from R0603 to R0402 to match PCB layout	Page3	Austin Lin	Brian Lee	Barry Chang
02	2013.07.15	Modify power circuit BOM value for finr tune power sequence, detail as below. Change C19 from 47nF to 22nF (footprint=C0402A) Change R35 from NC_51K ohm to NC_150K ohm (footprint=R0402A) Change R70 from 150K ohm to 51K ohm (footprint=R0402A) Change R38 from NC_51K ohm to NC_150K ohm (footprint=R0402A)	Page3	Brian Lee	Austin Lin	Barry Chang
02	2013.08.16	For Schematic cannot open correctly in ORCAD10.3 Korea language issue. Modify below part ORCAD library: 1. U14, SPI flash 2. SD1, schottky diode	Page3	Brian Lee	Austin Lin	Barry Chang
10	2013.08.30	1. Delete A1V2 LDO power supply circuit. Delete U7, 2. For improve SATA DEVSLP power consumption 2.1 Modify LDO U4 output net-name. 2.2 Add NMOS Q2, R42=86K, R43=51K, C33=1uF for adjust VCCK=1.0V at SATA DEVSLP mode. 2.3 Add VCCIO power supply option circuit (L4,L15,L16,L17) 3. Delete U12 external 2.7V VDT. Reserve GPIO P17 for future used. 4. Delete SPI flash (U13,BC45,R68) 5. Change 3.3Vto1.8V LDO U4 (Flash IO power) from SOT-23 (300mA) to SOT-89-5 (800mA)	Page 2,3	Austin Lin	Brian Lee	Barry Chang
11	2013.10.21	1. Add Test Point to WE, REN_P, DQS_P and DQ 2. Add Hole	Page 2,3,4	Austin Lin	Brian Lee	Barry Chang
20	2013.11.19	Change power solution from AAT to Silergy	3	Brian Lee	Austin Lin	Barry Chang
20	2013.12.02	1. For fine tune SATA DEVSLP power consumption, change R43 from 10K ohm to NC. 2. For support PC power cable with 3.3V, change R12 from 0 ohm to schottky diode / PKG: SOD523, if SOD723 is better.	2,3	Brian Lee	Austin Lin	Barry Chang

Page1	Cover_Page
Page2	Controller_BGA288_2.5INCH
Page3	Power_Host_5V
Page4	NF_BGA152x8 (CH0, CH1)
Page5	NF_BGA152x8 (CH2, CH3)
Page6	DRAM_DDR3
Page7	Flash Mounting Guide

 Silicon Motion, INC.	
PageTitle	Cover Page
DOC.Number	<Doc>
Sch.FileName	SM2246AA_BGA288_2.5INCH_BGA152X16_DB_V20
Date:	Tuesday, October 21, 2014
Esheet	1 of 7
Rev	20

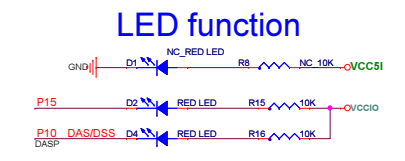
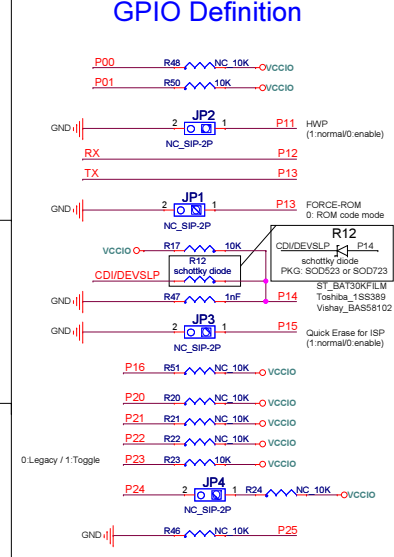
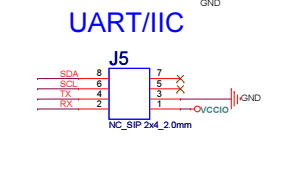
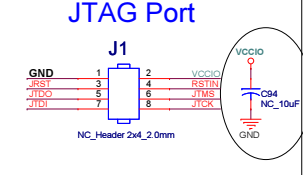
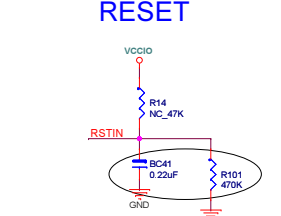
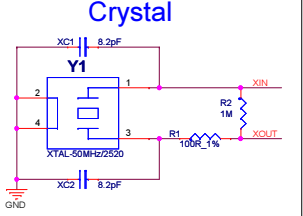
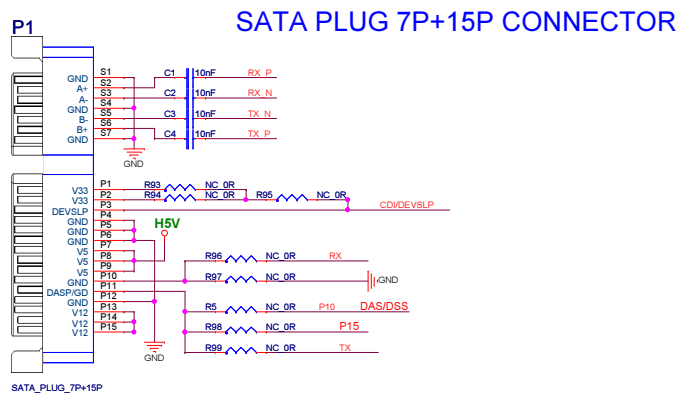

Controller

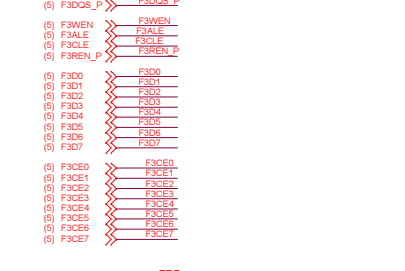
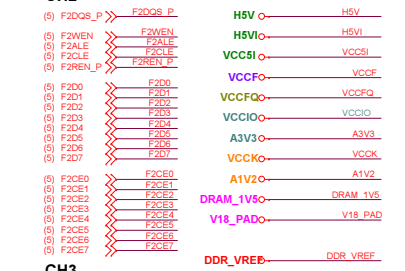
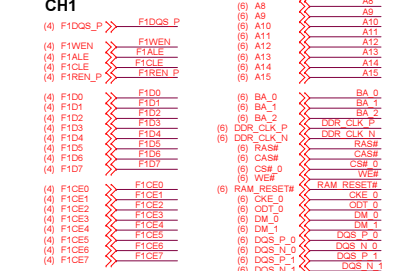
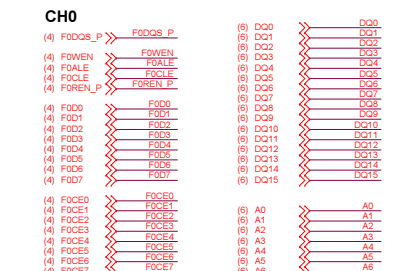
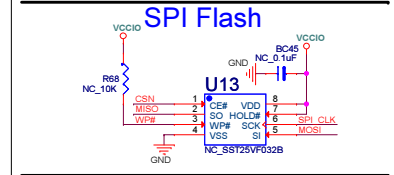
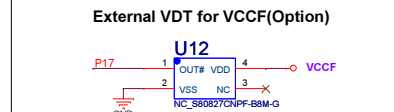
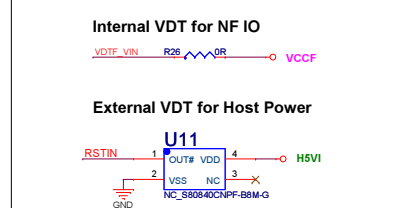
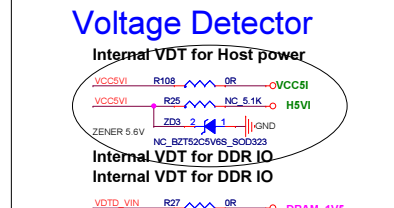
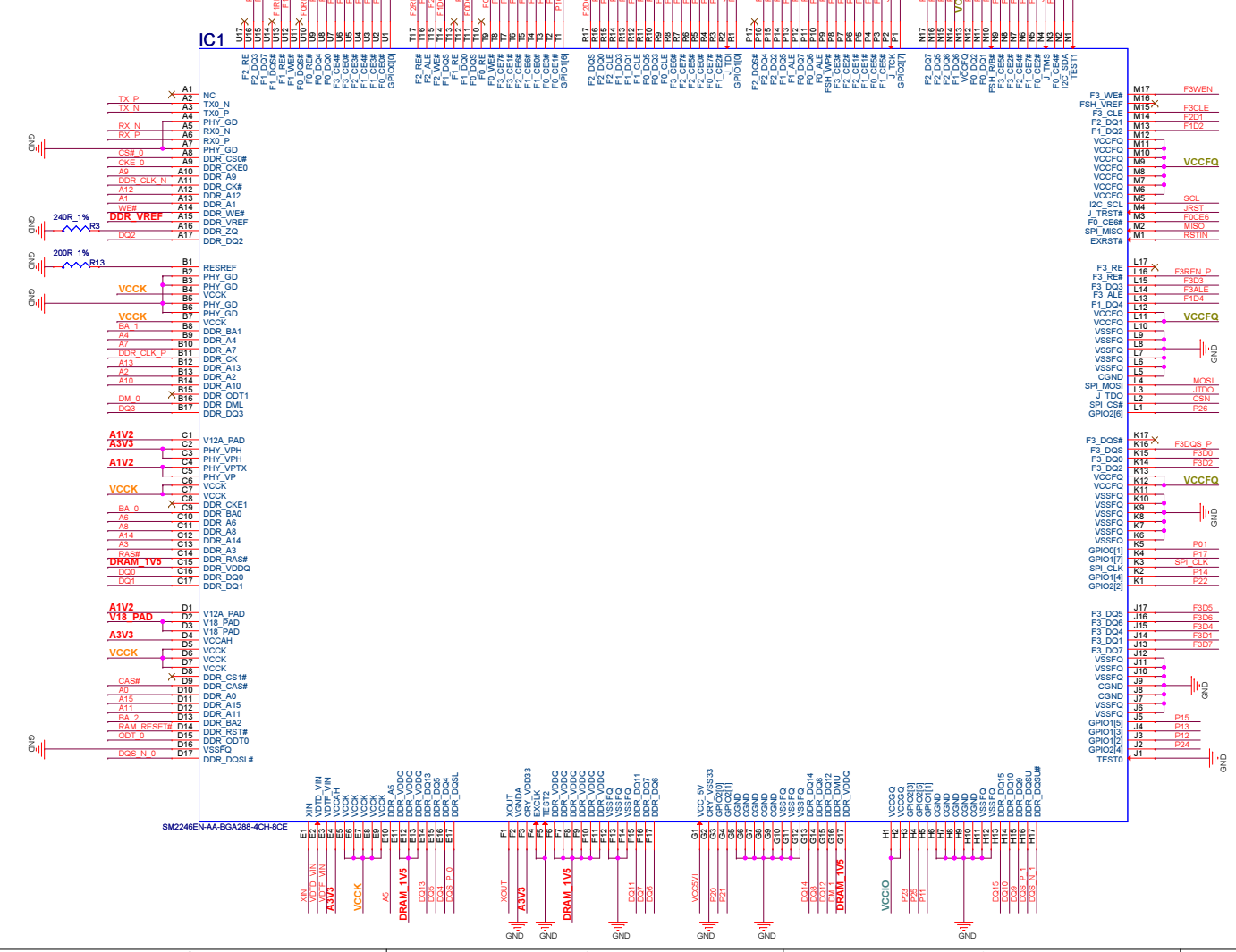

SM2246AA Bypass Capacitors

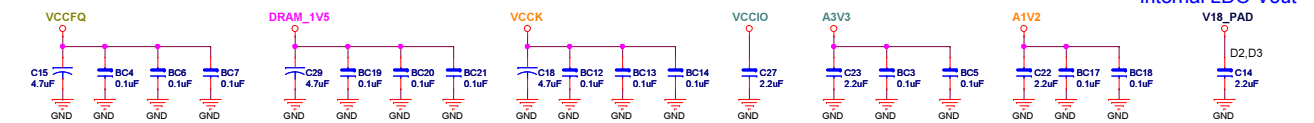

V18_PAD = SM2246 Internal LDO Vout

V18_PAD = SM2246 Internal 1.8V LDO Vout
 A3V3= 3.0 / 3.3 / 3.6 (V) For AIP power
 A1V2=VDDTX_PHY=VDDR_X_PHY= 1.14 / 1.2 / 1.26 (V) For AIP power
 VCCCK = 1.2 (V) For SM2246AA core power
 VCC = 3.3 / 1.8 (V) For General IO power
 VCCF = 3.3 (V) For NAND flash Core Power
 VCCFQ = 3.3 / 1.8 (V) For NAND flash IO Power
 DRAM_1V5 = 1.5 / 1.8 (V) For DRAM Power

OVP Circuit

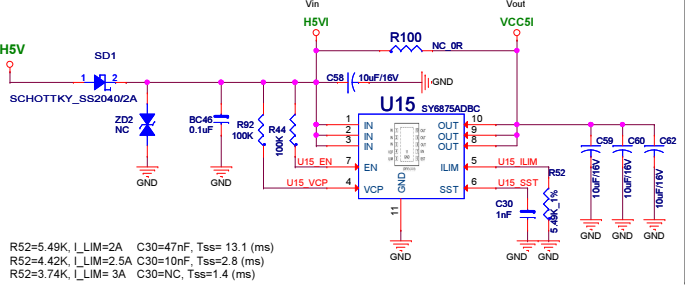

PWM_2 for Flash Die Power 3.3V

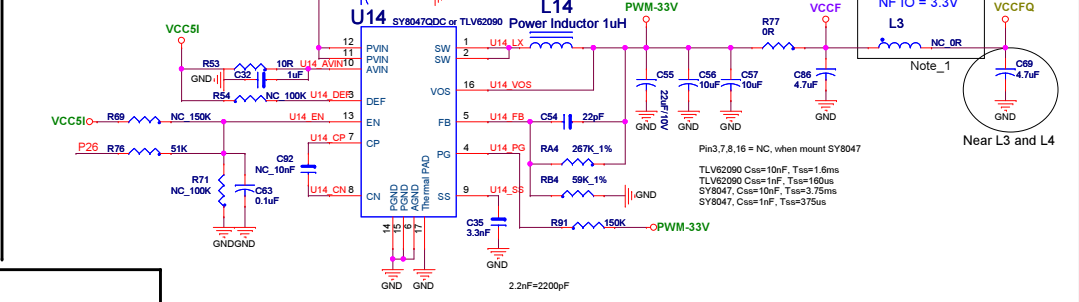

PWM_1 for VCCK/A1V2 1.2V

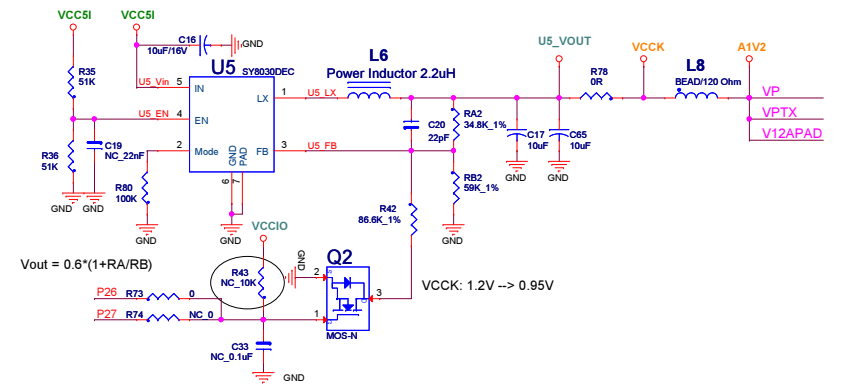

PWM_3 for Flash I/O 1.8V

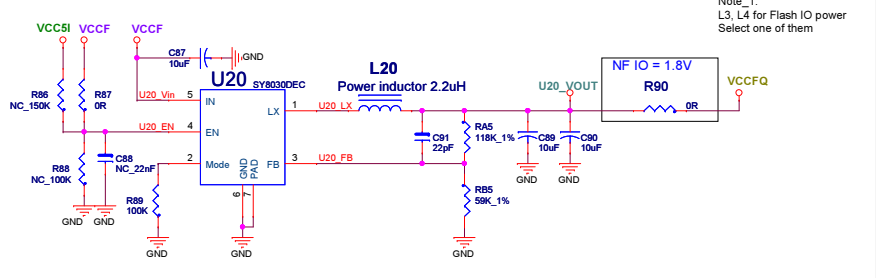

PWM_4 for DRAM-DDR3 1.5V

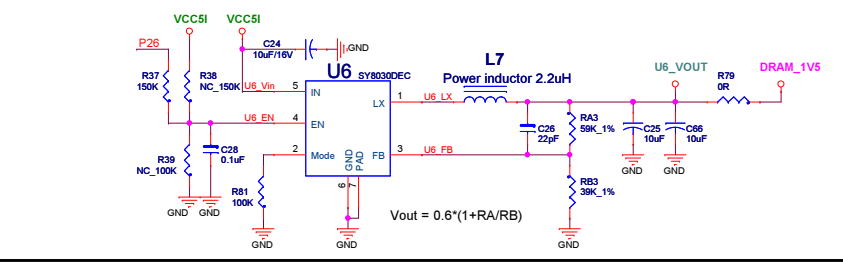

LDO_2: Analog Power 3.3V

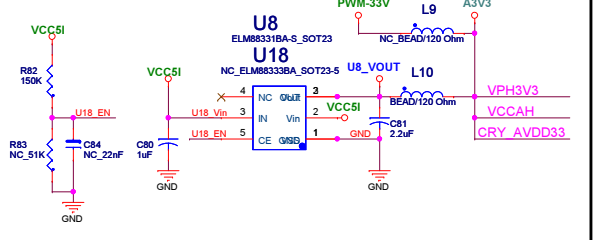

LDO_3: VCCIO Power 1.8V

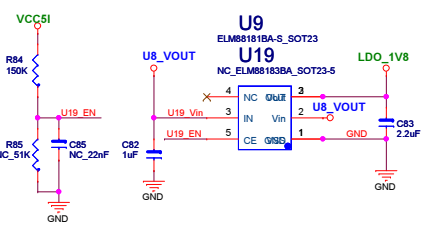

Note_2

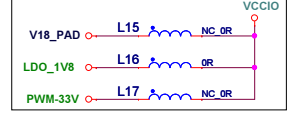

Note_2:
 VCCIO(GPIO VCC) power supply option circuit
 1.With DEVSLP Low Power SPEC
 Flash I/O =3.3V, select L16 or L15
 Flash I/O =1.8V, select L16
 2.Without DEVSLP Low Power SPEC
 Flash IO=3.3V or 1.8V, Select L17

- (2) P26 >> P26
- (2) P27 >> P27
- H5V >> H5V
- H5VI >> H5VI
- VCC5I >> VCC5I
- VCCF >> VCCF
- VCCFQ >> VCCFQ
- VCCIO >> VCCIO
- A3V3 >> A3V3
- VCCK >> VCCK
- A1V2 >> A1V2
- DRAM_1V5 >> DRAM_1V5
- V18_PAD >> V18_PAD
- DDR_VREF >> DDR_VREF

DRAM-DDR3

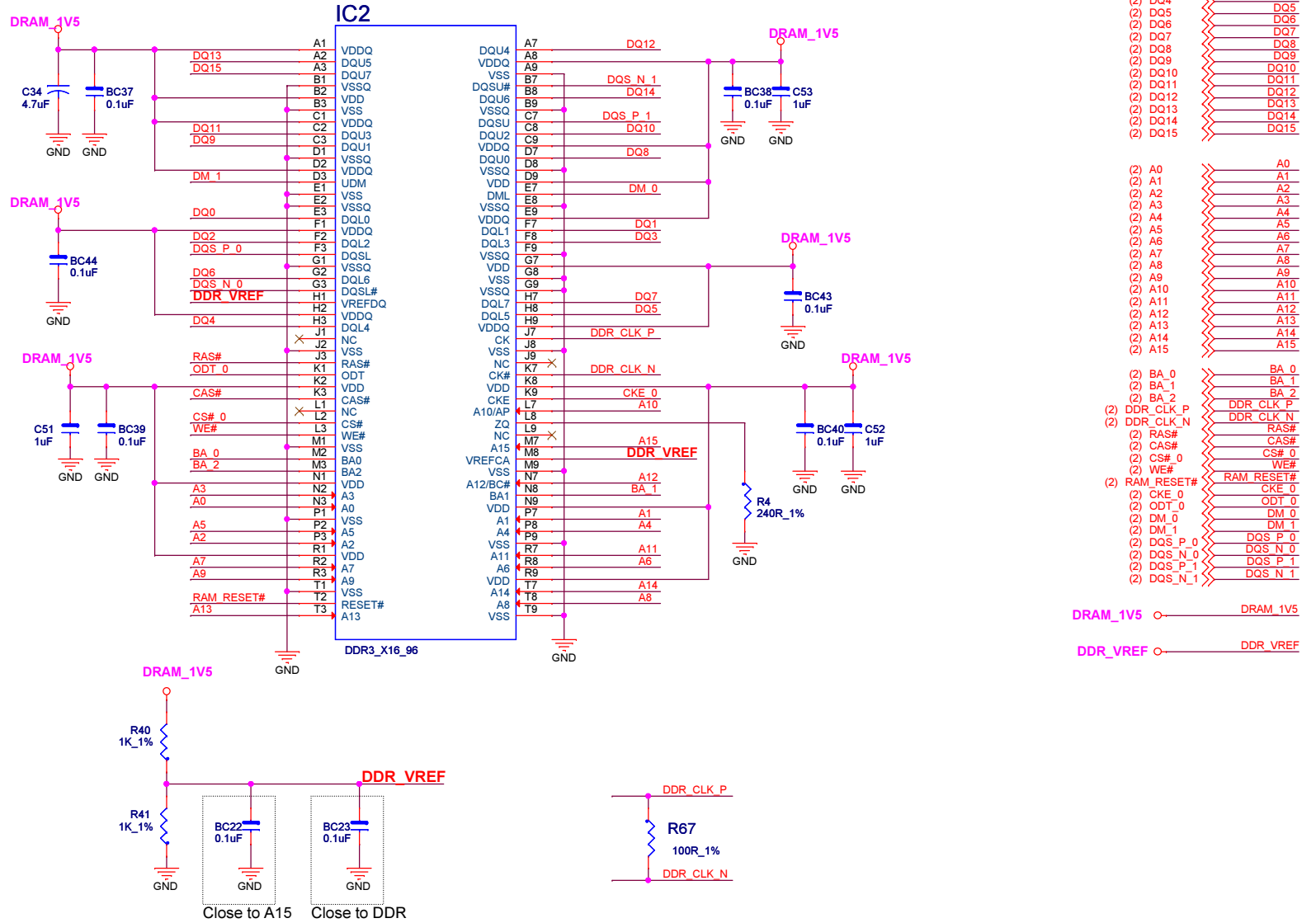

(2) DQ0	>>>	DQ0
(2) DQ1	>>>	DQ1
(2) DQ2	>>>	DQ2
(2) DQ3	>>>	DQ3
(2) DQ4	>>>	DQ4
(2) DQ5	>>>	DQ5
(2) DQ6	>>>	DQ6
(2) DQ7	>>>	DQ7
(2) DQ8	>>>	DQ8
(2) DQ9	>>>	DQ9
(2) DQ10	>>>	DQ10
(2) DQ11	>>>	DQ11
(2) DQ12	>>>	DQ12
(2) DQ13	>>>	DQ13
(2) DQ14	>>>	DQ14
(2) DQ15	>>>	DQ15
(2) A0	>>>	A0
(2) A1	>>>	A1
(2) A2	>>>	A2
(2) A3	>>>	A3
(2) A4	>>>	A4
(2) A5	>>>	A5
(2) A6	>>>	A6
(2) A7	>>>	A7
(2) A8	>>>	A8
(2) A9	>>>	A9
(2) A10	>>>	A10
(2) A11	>>>	A11
(2) A12	>>>	A12
(2) A13	>>>	A13
(2) A14	>>>	A14
(2) A15	>>>	A15
(2) BA_0	>>>	BA_0
(2) BA_1	>>>	BA_1
(2) BA_2	>>>	BA_2
(2) DDR_CLK_P	>>>	DDR_CLK_P
(2) DDR_CLK_N	>>>	DDR_CLK_N
(2) RAS#	>>>	RAS#
(2) CAS#	>>>	CAS#
(2) CS#_0	>>>	CS#_0
(2) WE#	>>>	WE#
(2) RAM_RESET#	>>>	RAM_RESET#
(2) CKE_0	>>>	CKE_0
(2) ODT_0	>>>	ODT_0
(2) DM_0	>>>	DM_0
(2) DM_1	>>>	DM_1
(2) DQS_P_0	>>>	DQS_P_0
(2) DQS_N_0	>>>	DQS_N_0
(2) DQS_P_1	>>>	DQS_P_1
(2) DQS_N_1	>>>	DQS_N_1

DRAM_1V5 ○ ——— DRAM_1V5
 DDR_VREF ○ ——— DDR_VREF

PageTitle	DRAM_DDR3
DOC.Number	<Doc>
Sch.FileName	SM2246AA_BGA288_2.5INCH_BGA152X16_DB_V20
Date:	Tuesday, October 21, 2014
Esheet	6 of 7
Rev	20

NAND FLASH Mounting Guide

2.5INCH BGA152x16 NAND Flash Mounting Guide																																				
NAND Flash Type	F1	F2	F3	F4	F5	F6	F7	F8	F9	F10	F11	F12	F13	F14	F15	F16	NF Config.	RCE1	RCE2	RCE3	RCE4	RCE5	RCE6	RCE7	RCE8	RCE9	RCE10	RCE11	RCE12	RCE13	RCE14	RCE15	RCE16	CE usage		
Single CE flash x1	⊗	X	X	X	X	X	X	X	X	X	X	X	X	X	X	X	1CH/1CE	△	△	△	△	△	△	△	△	△	△	△	△	△	△	△	△	CE0		
Single CE flash x2	⊗	⊗	X	X	X	X	X	X	X	X	X	X	X	X	X	X	2CH/1CE	△	△	△	△	△	△	△	△	△	△	△	△	△	△	△	△	CE0		
Single CE flash x3	⊗	⊗	X	X	X	X	X	X	⊗	X	X	X	X	X	X	X	3CH/1CE	△	△	△	△	△	△	△	△	△	△	△	△	△	△	△	△	CE0		
Single CE flash x4	⊗	⊗	X	X	X	X	X	X	⊗	⊗	X	X	X	X	X	X	4CH/1CE	△	△	△	△	△	△	△	△	△	△	△	△	△	△	△	△	CE0		
Single CE flash x8	⊗	⊗	X	X	X	X	X	X	⊗	⊗	X	X	X	X	X	X	4CH/2CE	△	△	△	△	△	△	△	△	△	△	△	△	△	△	△	△	CE0,CE4		
Single CE flash x16	⊗	⊗	⊗	⊗	⊗	⊗	⊗	⊗	⊗	⊗	⊗	⊗	⊗	⊗	⊗	⊗	4CH/4CE	△	△	△	△	△	△	△	△	△	△	△	△	△	△	△	△	CE0,CE2,CE4,CE6		
Dual CE flash x1	⊗	X	X	X	X	X	X	X	X	X	X	X	X	X	X	X	2CH/1CE	X	⊗	△	△	△	△	△	△	△	△	△	△	△	△	△	△	CE0		
Dual CE flash x2	⊗	⊗	X	X	X	X	X	X	X	X	X	X	X	X	X	X	2CH/2CE	⊗	X	△	△	△	△	△	△	△	△	△	△	△	△	△	△	CE0,CE1		
Dual CE flash x2	⊗	X	X	X	X	X	X	X	⊗	X	X	X	X	X	X	X	4CH/1CE	X	⊗	X	⊗	△	△	△	△	△	△	△	△	△	△	△	△	CE0		
Dual CE flash x4	⊗	⊗	X	X	X	X	X	X	⊗	⊗	X	X	X	X	X	X	4CH/2CE	⊗	X	⊗	X	△	△	△	△	△	△	△	△	△	△	△	△	CE0,CE1		
Dual CE flash x8	⊗	⊗	X	X	⊗	⊗	X	X	⊗	⊗	X	X	⊗	⊗	X	X	4CH/4CE	⊗	X	⊗	X	△	△	△	△	△	△	△	△	△	△	△	△	CE0,CE1,CE4,CE5		
Dual CE flash x16	⊗	⊗	⊗	⊗	⊗	⊗	⊗	⊗	⊗	⊗	⊗	⊗	⊗	⊗	⊗	⊗	4CH/8CE	⊗	X	⊗	X	△	△	△	△	△	△	△	△	△	△	△	△	CE0,CE1,CE2,CE3 CE4,CE5,CE6,CE7		
Quad CE flash x1	⊗	X	X	X	X	X	X	X	X	X	X	X	X	X	X	X	2CH/2CE	X	⊗	△	△	X	⊗	△	△	△	△	△	△	△	△	△	△	CE0,CE2		
Quad CE flash x2	⊗	⊗	X	X	X	X	X	X	X	X	X	X	X	X	X	X	2CH/4CE	⊗	X	△	△	⊗	X	△	△	△	△	△	△	△	△	△	△	CE0,CE1,CE2,CE3		
Quad CE flash x2	⊗	X	X	X	X	X	X	X	⊗	X	X	X	X	X	X	X	4CH/2CE	X	⊗	X	⊗	X	⊗	X	⊗	△	△	△	△	△	△	△	△	CE0,CE2		
Quad CE flash x4	⊗	⊗	X	X	X	X	X	X	⊗	⊗	X	X	X	X	X	X	4CH/4CE	⊗	X	⊗	X	⊗	X	⊗	X	△	△	△	△	△	△	△	△	△	CE0,CE1,CE2,CE3	
Quad CE flash x8	⊗	⊗	X	X	⊗	⊗	X	X	⊗	⊗	X	X	⊗	⊗	X	X	4CH/8CE	⊗	X	⊗	X	⊗	X	⊗	X	△	△	△	△	△	△	△	△	△	CE0,CE1,CE2,CE3 CE4,CE5,CE6,CE7	
8 CE flash x1	⊗	X	X	X	X	X	X	X	X	X	X	X	X	X	X	X	2CH/4CE	X	⊗	X	⊗	X	⊗	X	⊗	△	△	△	△	△	△	△	△	△	CE0,CE2,CE4,CE6	
8 CE flash x2	⊗	X	X	X	X	X	X	X	⊗	X	X	X	X	X	X	X	4CH/4CE	X	⊗	X	⊗	X	⊗	X	⊗	X	⊗	X	△	△	△	△	△	△	CE0,CE2,CE4,CE6	
8 CE flash x4	⊗	X	X	X	X	X	X	X	⊗	⊗	X	X	X	X	X	X	4CH/8CE	⊗	X	⊗	X	⊗	X	⊗	X	⊗	X	⊗	X	△	△	△	△	△	△	CE0,CE1,CE2,CE3 CE4,CE5,CE6,CE7

M1023A

⊗	Install
X	un-install
△	Don't care (it is fine if resistor mouning or not.)

TOP View For Flash PCB Placement (SMI DEMO BOARD V20)

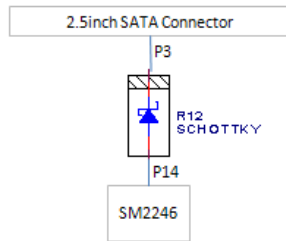
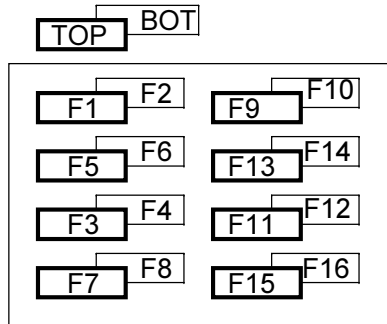

PageTitle	NF_Mounting_Guide
DOC.Number	<Doc>
Sch.FileName	SM2246AA_BGA288_2.5INCH_BGA152X16_DB_V20
Date:	Thursday, November 06, 2014
Esheet	7 of 7
Rev	20